



Digital Sensor System

GeoSIG's Digital Sensor System has been developed to accommodate the requirements for a cost effective and practical installation in circumstances where several measuring points need to be deployed over long distances.

The system consists of GMSplusD recorder and AC-7xD or AC-4xD digital accelerometers, with the option of adding analogue sensors.

Each digital accelerometer transfers its data digitally, accurately and effectively to the GMSplusD through a single cost effective Cat5E cable.

It is possible to connect up to 4 digital accelerometers (AC-7xD / AC-4xD) to a GMSplusD with a total length of 1'000 meters.

Additionally internal or external analogue sensors can be connected to the same GMSplusD to increase the number of monitored channels to 15.

Installation & Configuration

- ▶ Rugged aluminium housing with levelling base plate for fast and easy installation
- ▶ User-friendly web interface—easy to reach via web browser, tablets or smartphones
- ▶ Multiple advanced triggers with highly flexible configuration and combinations
- ▶ Easy configuration of interconnected networks with common timing and triggering

Data Acquisition & Analysis

- ▶ Event based and continuous ringbuffer recording with freely adjustable duration and period definitions
- ▶ Continuous realtime data streams in SEEDlink and GSBUS (low latency) formats
- ▶ Intelligent file management with user defined storage, transmission and lifetime allocation
- ▶ Smart and flexible time source options including RTC, NTP, GPS*, or interconnected network*

Features

- ▶ **High expandability**
Up to 15 channels through 3 analogue and 12 digital inputs. Easy and low cost installation.
- ▶ **Real-time data conversion and processing**
Acceleration, velocity and displacement
Low and highpass filtering, decimation
- ▶ **Reliability**
500'000 hours MTBF obtained from real field statistics
- ▶ **Reliable data**
for damage detection, decision making and post-event evaluation
Building code compliant (e.g. California, Panama, etc)
- ▶ **Self test**
Permanent self-monitoring without affecting its normal operation
User-configurable periodical state of health (SOH) report

Applications

- ▶ **Structural Health Monitoring (SHM)**
Residential, commercial, high-rise buildings, dams, bridges, pipelines, towers, damage and serviceability assessment
- ▶ **Monitoring for chemical, oil & gas industry**
Seismic alarm and safe shutdown
- ▶ **Ambient vibration testing & monitoring**
Operational modal analysis
Induced vibration monitoring and notification
- ▶ **Seismic and earthquake monitoring**
Earthquake Early Warning and Rapid Response earthquake monitoring networks
- ▶ **Disaster management**
Shake mapping & hazard mapping

Digital Sensor System

Specifications

Sensor

Various types of GeoSIG analogue sensors can be housed internally or connected externally, and up to four digital sensors can be connected externally to the GMSplusD. In case of internal sensor, the levelling is done on the base plate of the GMSplusD via its three levelling screws. The base plate is mounted using a single bolt during installation. All external sensors have built-in single bolt mounting with levelling screws.

Digitiser

Channels: up to 15:
 - 12 Ch (max. 4 sensors) for AC-7xD / AC-4xD digital sensors
 - 3 Ch for analog sensor

A/D conversion: 24 bit $\Delta-\Sigma$ converters individual for each channel

DSP: 32 bit output word length

Dynamic range: 146 dB (per bin @ 1 Hz rel. full scale rms)
 137 dB @ 50 sps

Sampling rate: 1000, 500, 250, 200, 100, 50 sps per channel

Max. bandwidth: DC to 250 Hz, optionally DC to 500 Hz
 3 or 4 digital sensors per chain; 120 Hz
 2 digital sensors per chain; 250 Hz
 1 digital sensor per chain; 500 Hz*

Anti aliasing filter: Analog and digital FIR (finite impulse response)

Recorder

Operating system: GNU/Linux

Triggering

Several trigger sets can be defined in the instrument. Each set can be flexibly configured regarding the source of trigger, main and advanced trigger parameters, trigger processing and selected channels for storage. A voting logic based on the monitored channels can be defined.

Trigger Filter

Fully independent high-, low- or bandpass trigger filters can be configured.

Level Triggering

User adjustable threshold.

STA/LTA Triggering

User adjustable STA / LTA values and STA/LTA trigger and dettrigger ratio.

Event Recording

Pre-event memory: 1 to 720 seconds, typical

Post-event duration: 1 to 7200 seconds, typical

Event Summary and Parameters

Content: PGA, PGV, PGD, SA (at 0.3, 1, 3 Hz)

Transmission delay: User defined from trigger time

Ring Buffer

Usage: User can request an event from any period of the ring buffer by specifying the start time date and the duration from the console or remotely from a server.

Method: Ringbuffer files with configurable duration which can be uploaded automatically to data server.

Data Stream

Protocol/compatibility: GSBUS, SeedLink, compatible to Earthworm

Storage Memory

Size and type: 8 GByte removable SD card, Optionally compact flash card higher capacity up to 128 GByte on request FAT32 or EXT4 formatted

Management: Intelligent management of memory card capacity using policies as per file type and ring buffer capacity specification.

Recording format: miniSEED with extended information encapsulated into blockette 2000

Estimated capacity: Sampling rate [sps] x 0.4 [MB/day/3 channel] (example: 40 MByte / day / 3 channel @ 100 sps) typical, since the data is compressed, capacity depends on the context of the data.

Housing

Type: Cast aluminium housing

Dimensions: Recorder: 296 x 225 x 156 mm
 Accelerometer: 195 x 112 x 95 mm

Weight: Recorder: 4.5 kg
 Accelerometer: 2.5 kg

Protection: IP65 (NEMA 4), or better*

Environment / Reliability

Operational temp: -20 to +70 °C**

Storage temperature: -40 to +85 °C**

Humidity: 0 to 100 % RH (non-condensing)

MTBF: > 500'000 hours

Timing System

Internal: Intelligent Adaptive Real Time Clock (IARTC)

External: NTP, GPS*, Wired Interconnection*

Free running

drift of TCXO: ±0.5 ppm (15 s/year) @ +25 °C
 ±2.5 ppm (75 s/year) @ -10 to +50 °C

Accuracy to UTC with NTP: < ±4 ms typical

Accuracy to UTC with GPS: < ±10 us typical

Power

Input voltage: 15 VDC (12.5 - 18 VDC) or wider*

Average consumption: GMSplusD: 200mA @ 12 VDC

AC-7xD: 200 mA @ 12 VDC per sensor

Cable loss: 35 mA @ 12 VDC per 100 m

Consumption of analogue sensor (if used) should be considered.

Indicators

● Green: Active charge LED

● Green: Run/stop LED

● Yellow: Event/memory LED

● Blue: Network link/traffic LED

● Red: Warning/error LED

Communication

Configuration, Data retrieval: Via Ethernet, Wi-Fi*, serial line, console, or directly via removable memory card.

Network requirements: Fixed or dynamic IP on Ethernet LAN and/or Internet connection with Ethernet interface OpenVPN*; Wi-Fi (b/g/n) network with WEP, WPA, WPA2, security and enterprise mode

Security: GeoDAS proprietary protocol over SSL

Checksum and software handshaking

Serial ports: 2 ports standard, + 3 ports optional

Baud rates: Console: 115200 baud

Serial Stream: 38400, 57600, 115200 baud

Digital Sensor System

Specifications (continued)

Output & Alarms

- ▶ Data output in industry compatible format: miniSEED as well as enhanced miniSEED format
- ▶ Data interface/conversion to specialised software: such as Artemis Extractor, MATLAB, SEISAN, etc
- ▶ Earthquake early warning and rapid response*: approved by Japan International Cooperation Agency (JICA)
- ▶ Alarm functions*: via SMS, Email, audible or direct interface (relays)

Communication & Remote Management

- ▶ Simultaneous data streaming to several clients
- ▶ Full remote management, maintenance & software updates
- ▶ Simple and secure wireless communication*
- ▶ Communication via wired Ethernet and serial links
- ▶ Enhanced connectivity via cellular or satellite devices*
- ▶ USB interface for communication devices

Frequently Asked Questions

- Q1. What is the difference between GMSplus and GMSplusD?**
A1. GMSplusD is a GMSplus with additional hardware and firmware to allow for connecting GeoSIG digital sensors.
- Q2. What is the difference between AC-73 and AC-73D?**
A2. AC-7xD is an AC-7x with additional hardware and firmware to enable a digital signal output.
- Q3. What is the maximum cable length for the digital sensors?**
A3. The maximum entire length of the cable on the digital sensor chain is 1'000 meters; contact GeoSIG for further details.
- Q4. What is the maximum possible number of sensors?**
A4. There can be up to 4 digital AC-7xD / AC-4xD sensors and one analogue sensor (e.g. AC-7x, VE-5x, etc). The analogue sensor can be either an internal sensor where possible, mounted inside the GMSplus or an external sensor.
- Q5. What is the maximum cable length for the analogue sensor that can be externally connected to the GMSplusD?**
A5. This depends on the type of the sensor used. Please consult GeoSIG for specific information.
- Q6. Why are there two types of cables? Ethernet Cat5E and Sensor cable?**
A6. Digital signal requires less bandwidth and is more immune to interference, therefore a standard inexpensive Ethernet Cat5E cable can be used. The analogue sensor requires a special sensor cable to ensure that the signal quality and characteristics are maintained and is protected against interference.
- Q7. What is the power autonomy of the system?**
A7. The autonomy depends on the number of the sensors and the amount of cable used. If an internal battery is used in the GMSplusD can provide up to 6 hours autonomy with 4 digital sensors connected. External battery solutions are optionally available to support a GMSplusD using the maximum amount of sensors.
- Q8. Can you use a different sensor with GMSplusD?**
A8. Currently only AC-7xD or AC-4xD can be used as digital sensors, however, the analogue sensor can be any GeoSIG sensor or any other compatible third party sensor.
- Q9. Can you use a uniaxial AC-71D or biaxial AC-72 with the GMSplus Digital?**
A9. Yes this is possible. Regardless of the sensor configuration (AC-71, AC-72 or AC-73), the maximum number of sensors remain the same: four digital sensors and one analogue sensor. The analogue connection allows for totally three channels which can be a combination of uniaxial or biaxial sensors.
- Q10. Can you network two or more GMSplusD systems to increase the number of measuring points?**
A10. Yes this is possible using any standard LAN. In case of special situations such as long distances, wireless applications, etc, GeoSIG has numerous options and solutions to accommodate for these.

Options*

Storage Memory

Size: up to 128 GByte
Type: Compact Flash Card

Timing System

Interconnection: Wired common time and trigger interconnection network, distributing GPS-grade time precision among several units.

Alarm / Seismic Switch / Warning / Notification

Alarms: 3 independent or 4 common relay contacts for trigger alarm and/or error SMS notification

Alarm levels: Configurable based on event triggers (NO or NC selectable during order)

Relay Hold-On: 1 to 60 seconds (user programmable)

Capacity: The contacts are suitable for a low voltage control. In case a large load must be switched then external relays should be implemented.

Max voltage: 125 V / 250 mA

Early Warning

Please contact GeoSIG for the optional Earthquake Early Warning functionality.

Communication

Modem: External modems of different types, including cellular 3G/4G modems, are available.

Serial ports: up to 3 additional serial ports can be enabled; please contact GeoSIG for details.

Power

Input voltage: 9 - 36 or 18 - 75 VDC

Power source: External power block:
90 - 260 VAC / 50 - 60 Hz to 15 VDC, 40W switched, UL External GeoSIG Power Pack including power block:
90 - 260 VAC / 50 - 60 Hz to 15 VDC, 60W switched UL

Battery: Internal 7 or 9 Ah lead acide battery, which can be supplied inside separate Battery Pack

Housing

Protection: IP67 (NEMA 6)

Transport: Portability accessories are available to facilitate short term measurements

GMSplus & AC series are produced in different types to suit particular specifications or regulations. Specifications mentioned in this datasheet may be different among different types.

* Option. May require third party devices, software and/or services which may not typically be provided by GeoSIG. Not all options can be used together.

** Use of an internal battery may degrade this specification.

[Link to GMSplus response files in IRIS NRL library](#)

[Link to AC-73 accelerometer response files in IRIS NRL library](#)

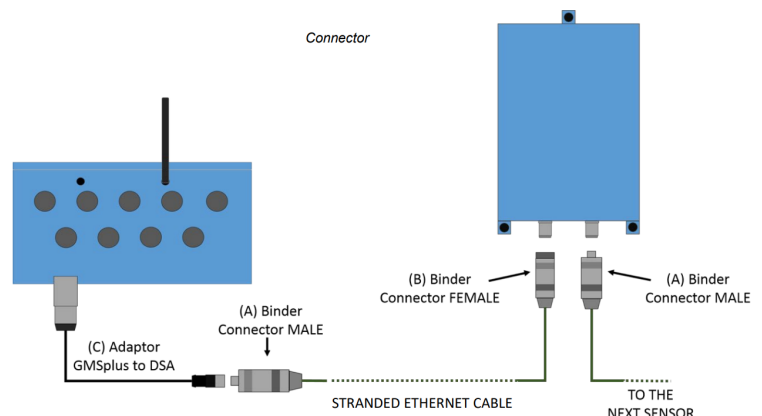

Digital Sensor System

Example Topologies

Chain

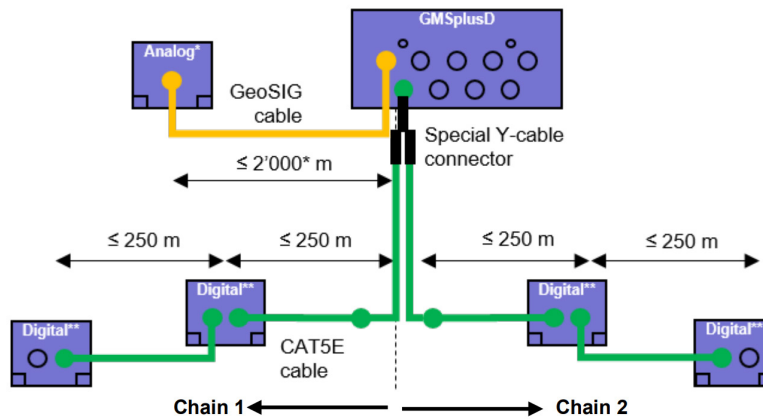
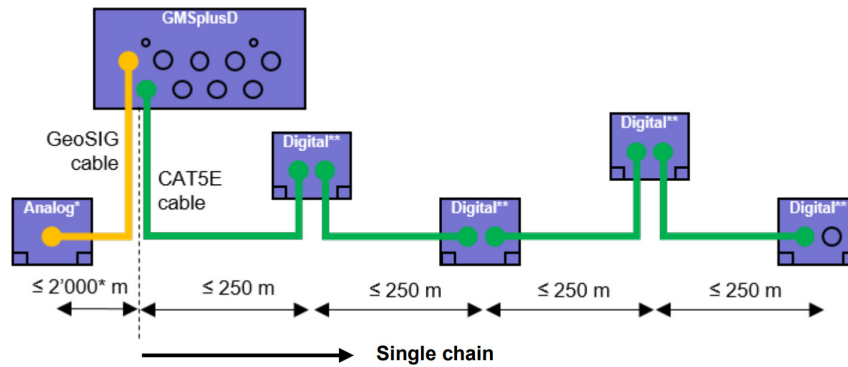

Multiple / Tree

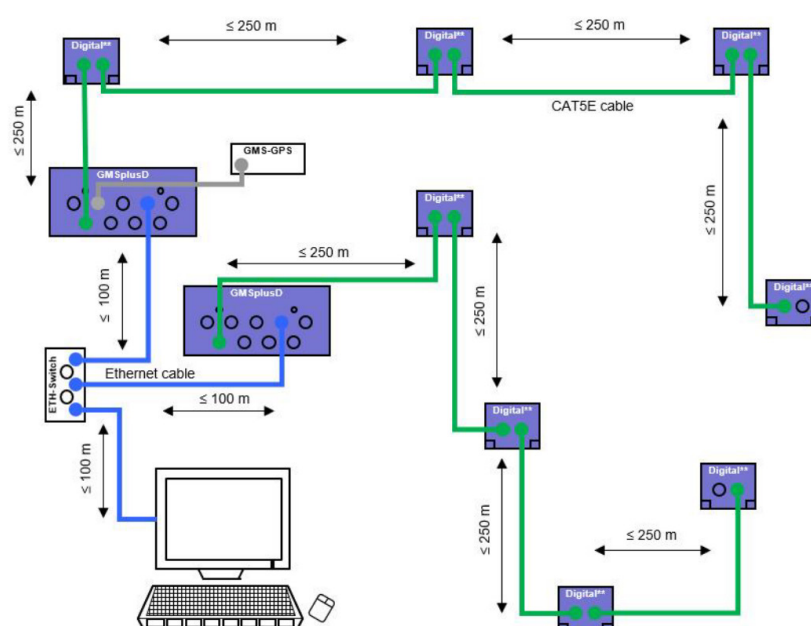

Refer to the user manual for allowable distances for fewer than 4 sensors.

* : The maximum cable length to analog sensor depends on the type of sensor, type of cable, and whether a SEN-JB junction box is used or not.
 ** : Currently AC-4x or AC-7x series are provided in digital version